



# **KING STREET WATER TREATMENT PLANT**

## **2024 ANNUAL REPORT**

**Drinking Water System Number:** 220001860  
**Drinking Water System Owner:** City of Kingston  
**Drinking Water System Category:** Large Municipal Residential

**TABLE OF CONTENTS**

1 EXECUTIVE SUMMARY..... 4

2 PLANT DESCRIPTION AND TREATMENT PROCESS ..... 4

2.1 RAW WATER SOURCE..... 4

2.2 ZEBRA MUSSEL CONTROL..... 4

2.3 PRE-CHLORINATION ..... 4

2.4 SCREENING..... 4

2.5 LOW LIFT PUMPS ..... 4

2.6 COAGULATION / FLOCCULATION..... 4

2.7 MIXING TANKS..... 4

2.8 SETTLING TANKS ..... 5

2.9 FILTERS ..... 5

2.10 BACKWASH..... 5

2.11 PROCESS WASTE FACILITY..... 5

2.12 POST CHLORINATION ..... 5

2.13 CLEAR WELL..... 5

2.14 HIGH LIFT PUMPS..... 5

2.15 STANDBY EQUIPMENT ..... 5

Figure 1 – King Street Water Treatment Plant Process Flow Diagram ..... 6

Figure 2 – Kingston Distribution System Process Flow Diagram ..... 7

3 DISTRIBUTION SYSTEM ..... 8

3.1 DISTRIBUTION AREA 1 ..... 8

3.2 DISTRIBUTION AREA 2 ..... 8

3.3 DISTRIBUTION AREA 3 ..... 8

4 MONETARY EXPENSES..... 8

4.1 MAJOR EXPENSES: ..... 8

5 NOTIFICATIONS..... 9

5.1 EVENTS REQUIRING NOTIFICATIONS: ..... 9

6 GLOSSARY ..... 10

7 WATER QUALITY TEST RESULTS ..... 11

Table 1 - Microbiological Testing ..... 11

Table 2 - Operational Testing ..... 11

Table 3 - Filter Operational Testing ..... 11

Table 4 - Process Waste Facility Effluent Testing and Sampling ..... 12

Table 5 - Additional Process Waste Facility Effluent Testing and Sampling ..... 12

Table 6 - Raw Water Testing ..... 12

Table 7 - Treated Water Schedule 23 Inorganic Parameters ..... 14

Table 8 - Treated Water Schedule 24 Inorganic Parameters ..... 14

Table 9 - Other Regulatory Treated Water Parameters ..... 16

Table 10 - Treated Water Testing ..... 17

Table 11 - Regulatory Distribution Water Testing ..... 18

Table 12 - Lead Testing ..... 18

Table 13 - Distribution Water Testing ..... 19  
Table 14 - Raw Water Testing ..... 20  
Table 15 - Treated Water Testing ..... 21

## 1 EXECUTIVE SUMMARY

Utilities Kingston is proud to present this annual report on drinking water quality. This report has been prepared in accordance with Section 11 of Ontario Regulation 170/03. Regulation 170/03 sets requirements for public waterworks with regard to sampling and testing, levels of treatment, licensing of staff, and notification of authorities and the public about water quality. Free copies of this report and the Summary report prepared in accordance to Schedule 22 of Ontario Regulation 170/03, are available by public request at any City of Kingston offices, at our water plant locations, and at <http://www.utilitieskingston.com>. Notices of availability are generally made through our website and media releases on social media platforms. More information on the Drinking Water Regulations can be found on the [Ministry of the Environment, Conservation and Parks](#) (MECP) website. For further information about this report or any questions regarding accessibility, contact Robert Cooney by email at [rcooney@utilitieskingston.com](mailto:rcooney@utilitieskingston.com), or call 613-546-1181 Ext 2291.

## 2 PLANT DESCRIPTION AND TREATMENT PROCESS

### 2.1 RAW WATER SOURCE

The source of water treated by this plant is Lake Ontario at the mouth of the St. Lawrence River. The intake is located 1 km directly south of the treatment plant, 4 m off the lake bottom, at a depth of approximately 18 m. A great deal of testing was carried out in choosing the location for the intake. This has ensured that the treatment process begins by using the best and most consistent quality source water available and reduces its susceptibility to contamination. Known sources of potential problems are few, and response plans are in place in the event of raw water contamination.

### 2.2 ZEBRA MUSSEL CONTROL

When the water temperature rises above 10°C (above this temperature zebra mussels are active), pre-chlorination takes place at the mouth of the intake. This protects the intake from becoming encrusted with zebra mussels, which would restrict the flow of water through the intake.

### 2.3 PRE-CHLORINATION

The purpose of chlorination is to provide disinfection. 12% sodium hypochlorite is applied to the raw water in solution form.

### 2.4 SCREENING

A revolving screen in the suction well of the low lift building removes any large debris such as weeds, fish, etc.

### 2.5 LOW LIFT PUMPS

These pumps lift the water from lake level to the main plant. There are two pipes from the low lift building directing the water to the mixing chambers.

### 2.6 COAGULATION / FLOCCULATION

Poly Aluminum Chloride (PACl) is used as the coagulant for the treatment process. The coagulant is added to the water as it leaves the low lift building.

### 2.7 MIXING TANKS

Water flows rapidly in these tanks in a spiral motion, allowing proper mixing of the chlorine and alum with the water. The particles in the water will collide with the PACl particles, and then join together to form larger particles called floc.

## 2.8 SETTLING TANKS

These are large tanks designed to reduce the velocity of water allowing the heavier floc particles to settle out. They also provide detention time, allowing the chlorine time to achieve disinfection.

## 2.9 FILTERS

Six rapid sand filters with Granular Activated Carbon (GAC) and anthracite remove the particles that did not settle out in the settling tanks, as well as compounds that may cause tastes and odours. Water flows through the filters to a clean water reservoir called the clear well.

## 2.10 BACKWASH

Filters are washed daily to remove the particulates they have collected over the previous 24 hours. Clean water from the clear well is pumped backwards through the filter, and the top layer of the filter is agitated to break up any large particles. Effluent water from the backwash process is directed to a process waste facility for further treatment.

## 2.11 PROCESS WASTE FACILITY

Effluent from the filter backwash process and sludge from the settling process are directed to the process waste facility for further treatment. Effluent is directed to two equalization tanks at the head of the process. Magnafloc 120 L is added to the water as it is pumped from the equalization tanks through plate settlers at which time the supernatant from the process is de-chlorinated using a 30% Calcium Thiosulphate solution, and then directed back to Lake Ontario. The sludge produced during the process is then pumped to the sanitary sewer system for further treatment at the Ravensview Water Pollution Control Plant.

## 2.12 POST CHLORINATION

Sodium hypochlorite is added to the water as it enters the clear well to create a 'chlorine residual' which remains throughout the distribution system. This ensures protection to the point of the customers' tap.

## 2.13 CLEAR WELL

Filtered water is stored here before being pumped to the distribution system or used for filter washing.

## 2.14 HIGH LIFT PUMPS

Five high lift pumps move treated water from the clear well into the distribution system.

## 2.15 STANDBY EQUIPMENT

Diesel driven pumps are maintained to provide a continuous supply of water during power failures. These provide enough capacity to meet fire-fighting requirements as well as normal flows during power outages. A diesel generator provides electricity to run metering equipment and lighting in the water plant. Standby equipment is maintained for all critical processes.

DOCUMENT:  
King Street Water Treatment Plant Annual Report

Figure 1 – King Street Water Treatment Plant Process Flow Diagram

KING STREET WATER TREATMENT PLANT PROCESS FLOW

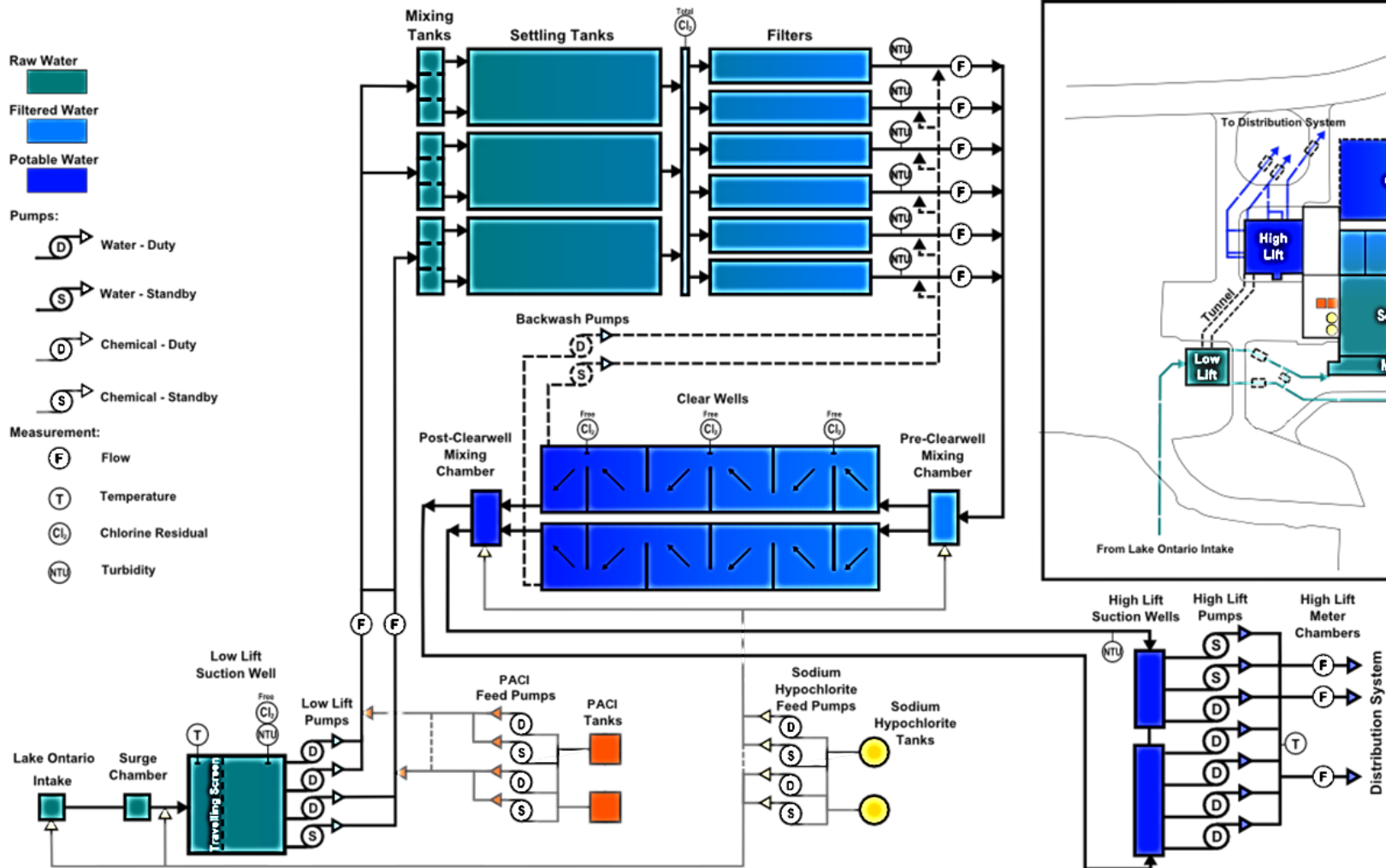
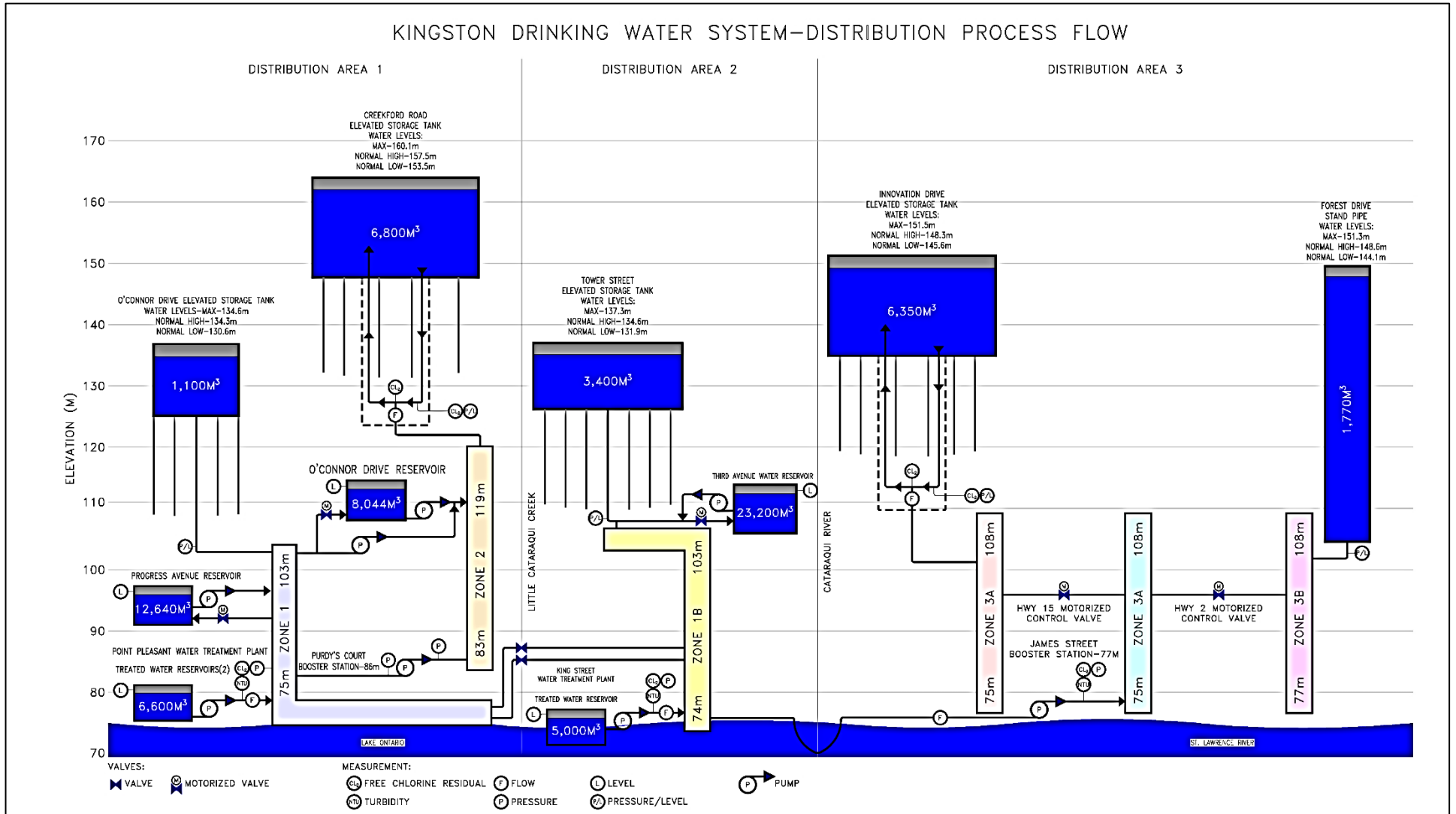

Figure 2 – Kingston Distribution System Process Flow Diagram



### 3 DISTRIBUTION SYSTEM

The Kingston Drinking Water System, which receives water from both the King Street Water Treatment Plant and the Point Pleasant Water Treatment Plant, has a service population of approximately 132,485 (population from Census data for 2021). The distribution system is divided into three distribution areas.

#### 3.1 DISTRIBUTION AREA 1

Distribution Area 1 is the area west of the Little Cataraqui Creek, south of Highway 401 and east of Coronation Boulevard, and north of Highway 401 along Sydenham Road northward to Mildred Street and eastward from Sydenham Road along Sunnyside Road for approximately 1.2 km. Distribution Area 1 is comprised of approximately 220 km of water mains, 2 ground level reservoir/pumping stations, 2 elevated storage tanks, 4 booster stations, over 2,500 main line valves, and over 1,300 fire hydrants and their associated isolation valves.

#### 3.2 DISTRIBUTION AREA 2

Distribution Area 2 is the area east of the Little Cataraqui Creek, west of the Cataraqui River, and south of Highway 401. A small area on the east side of the Cataraqui River upstream of the pumps at the James Street Booster Station is part of distribution Area 2. In addition, Collins Bay Institution, which is west of the Little Cataraqui Creek on Bath Road, is supplied with water from this area and from Area 1.

Distribution Area 2 is comprised of over 250 km of water mains, 1 ground level reservoir/pumping station, 1 elevated storage tank, over 2,000 main line valves, and over 1,200 fire hydrants and their associated isolation valves. The King Street Water Treatment Plant provides water to Distribution Area 2. The Tower Street Elevated Storage Tank and the Third Avenue Reservoir are located within this distribution area.

#### 3.3 DISTRIBUTION AREA 3

Distribution Area 3 is the area east of the Cataraqui River. Distribution Area 3 is comprised of over 70 km of water mains, 1 water booster station, 2 elevated storage facilities, over 250 main line valves, and over 300 fire hydrants and their associated isolation valves.

Water is supplied to Distribution Area 3 from Distribution Area 2 through the James Street Booster Station.

### 4 MONETARY EXPENSES

Under Section 11 of Ontario Regulation 170/03, a description of any major expenses incurred during this reporting period must be included in the annual report.

#### 4.1 MAJOR EXPENSES:

- Ongoing water main replacement programs continued throughout the City of Kingston.
- Ongoing leak detection, hydrant maintenance, and valve operation programs were conducted throughout the distributions system.
- Improvements were made to distribution pressure zone monitoring.
- A comprehensive facility condition assessment was completed.
- Complete water treatment plant PLC upgrades are ongoing.
- Ongoing work is being completed for the low lift diesel pumps.
- A treated water flow meter was replaced.
- Safety upgrades were completed for chemical drum handling equipment.



## DOCUMENT:

King Street Water Treatment Plant Annual Report

- GAC was replaced in two filters.
- A sump house pump was replaced.
- The chemical delivery pumps were replaced.
- Third Avenue Reservoir facility upgrades including pump replacement
- A variable frequency drive was replaced at O'Connor Drive Reservoir.
- The Old Colony Road Booster Station was decommissioned.
- Safety upgrades and pressure washing of Creekford Tower were completed.

## 5 NOTIFICATIONS

Under Ontario Regulation 170/03, notifications were required for any instances where a sample result indicated that a parameter used to measure water quality exceeded a Maximum Acceptable Concentration (MAC). Once a notification is received from a laboratory or an observation of any other indicator of adverse water quality is made by operations personnel, corrective action as dictated by the regulations is initiated in an effort to confirm the initial result. If confirmed, further action may be recommended by the Medical Officer of Health. If not confirmed, sampling will typically return to the normal schedule, or depending on the parameter, Utilities Kingston may choose to increase the sampling frequency to monitor the parameter more closely for a period of time.

### 5.1 EVENTS REQUIRING NOTIFICATIONS:

- An adverse water quality indicator notification was received from Caduceon Environmental Laboratories regarding a sample collected on **February 14<sup>th</sup>**, which was determined to have a Total Coliform (TC) count of **1 cfu/100mL**. The free chlorine residual at the time of sampling was **1.47 mg/L**. Notifications were made to the Spills Action Centre and to the Environmental Health Division of the local Ministry of Health. Resamples were collected from the same location, upstream and downstream, and sent to the lab for analysis. With the free chlorine residual present in the original sample and the subsequent re-samples not indicating any adverse conditions, a contaminated sample bottle or sampling error is suspected.
- Notification of a potential adverse water quality incident was provided to the Medical Officer of Health and Spills Action Centre on **April 29<sup>th</sup>**, due to an equipment malfunction which resulted in a failure to provide chemically assisted filtration to the affected filter, while water was being directed to the next step of the treatment process. No advisory was issued by the Medical Officer of Health as plant performance data and bacteriological sampling result indicated there was no risk to public health.
- Notification of a potential adverse water quality incident was provided to the Medical Officer of Health and Spills Action Centre on **July 7<sup>th</sup>**, when a water main break resulted in a loss of pressure for part of the distribution system. Residents experienced a loss of pressure while repairs were being completed. A boil water advisory was implemented for the affected area until two sets of bacteriological samples were tested and clear of E.coli and TC. A total of 22 samples were collected and the boil water advisory was lifted on **July 13<sup>th</sup>**.
- An adverse water quality indicator notification was received from Caduceon Environmental Laboratories regarding a sample collected on **September 26<sup>th</sup>**, which was determined to have a TC count of 6 cfu/100mL. The free chlorine residual at the time of sampling was **1.83 mg/L**. Notifications were made to the Spills Action Centre and to the Environmental Health Division of the local Ministry of Health. Resamples were collected from the same location, upstream and downstream, and sent to the lab for analysis. With the free chlorine residual present in the original sample and the subsequent re-samples not indicating any adverse conditions, a contaminated sample bottle or sampling error is suspected.

## 6 GLOSSARY

**TCU** – True Colour Units

**mg** – Milligram

**N/A** – Not Applicable

**N/D** – Non-Detectable

**NTU** – Nephelometric Turbidity Units - A measure of the amount of particles in water.

**mg/L** – Milligrams per litre. This is a measure of the concentration of a parameter in water, also called parts per million.

**µg/L** – Micrograms per litre, also called parts per billion.

**ng/L** – Nanograms per litre, also called parts per trillion.

**Parameter** – A substance that we sample and analyze for in the water.

**AO** – Aesthetic Objective. AOs are not health related, but may affect the taste, odour, colour, or clarity of the water

**OG** – Operational guideline. Set to ensure efficient treatment and distribution of water.

**MAC** – Maximum Acceptable Concentration. This is a health-related drinking water standard established for contaminants having known or suspected adverse health effects when above a certain concentration. The length of time the MAC can be exceeded without injury to health will depend on the nature and concentration of the parameter.

## 7 WATER QUALITY TEST RESULTS

**Table 1 - Microbiological Testing**

(Performed Under Regulation 170/03)

Location	MAC (E. Coli & Total Coliforms)	Number of Samples	Range of E. Coli Results (Min - Max)	Range of Total Coliform Results (Min - Max)	Number of HPC Samples	Range of HPC Results (Min - Max)
Raw	N/A	54	0 - 1	0 - 106	N/A	N/A
Treated	0	54	0	0	54	Under 10 - 20
Kingston Drinking Water System	0	1386	0	0 - 1	764	Under 10 - 290

Note: Total Coliforms are an indicator of adverse water quality if detected

**Table 2 - Operational Testing**

(Performed under Schedule 7, 8, or 9 of Regulation 170/03)

Parameter	MAC	Number of Samples	Range of Results (min - max)	Parameter Description
Raw Water Turbidity (NTU)	N/A	Continuous	0.067 - 1.11	Turbidity is a measure of particles in water
Treated Water Turbidity (NTU)	N/A	Continuous	0.042 - 0.172	Turbidity is a measure of particles in water
Treated Chlorine Residual (mg/L)	See Parameter Description	Continuous	1.14 - 3.17	Recommended level of at least 0.20 mg/l in distribution system to maintain microbiological quality. 0.05 mg/l minimum required.
James Street Booster Station Chlorine Residual (mg/L)	See Parameter Description	Continuous	0.93 - 3.13	Recommended level of at least 0.20 mg/l in distribution system to maintain microbiological quality. 0.05 mg/l minimum required.
Kingston Drinking Water System Chlorine Residual (mg/L)	See Parameter Description	Continuous	0.25 - 3.13	Recommended level of at least 0.20 mg/l in distribution system to maintain microbiological quality. 0.05 mg/l minimum required.

Note: Turbidity range determined through in house lab testing

**Table 3 - Filter Operational Testing**

Parameter	MAC	Number of Samples	Range of Results (min - max)	Results Average
Filter #1 Effluent Turbidity (NTU)	1.0 for over 15 minutes	Continuous	0.03 - 0.630	0.07
Filter #2 Effluent Turbidity (NTU)	1.0 for over 15 minutes	Continuous	0.03 - 0.290	0.07
Filter #3 Effluent Turbidity (NTU)	1.0 for over 15 minutes	Continuous	0.03 - 2.00	0.13
Filter #4 Effluent Turbidity (NTU)	1.0 for over 15 minutes	Continuous	0.03 - 0.240	0.112
Filter #5 Effluent Turbidity (NTU)	1.0 for over 15 minutes	Continuous	0.03 - 1.1	0.105
Filter #6 Effluent Turbidity (NTU)	1.0 for over 15 minutes	Continuous	0.040 - 0.470	0.09

**DOCUMENT:**  
King Street Water Treatment Plant Annual Report

**Table 4 - Process Waste Facility Effluent Testing and Sampling**

Parameter	MAC	Number of Samples	Results Average	Parameter Description
Total Suspended Solids (mg/L)	25	12	3.58	A measure of the particulates collected in the filtration process.
Chlorine Residual (mg/L)	Over 0.02	12	0.009	Residual of 0 mg/L as required by the drinking water licence for this facility

Note: Testing and sampling in accordance with the requirements of the Municipal Drinking Water Licence

**Table 5 - Additional Process Waste Facility Effluent Testing and Sampling**

Parameter	MAC	Number of Samples	Results Average	Parameter Description
BOD5 (mg/L)	N/A	12	3	Biological Oxygen Demand
Aluminum (mg/L)	N/A	12	0.66	Residual from treatment process
pH	N/A	12	7.9	An indicator of the acidity of water

**Table 6 - Raw Water Testing**

(Analyzed by Accredited Laboratories)

Parameter	MAC	Number of Samples	Results Range (min - max)	MAC Exceedance (Yes or No)	Parameter Description
Alkalinity as CaCO <sub>3</sub> (mg/L)	N/A	4	97 - 101	N/A	A measure of the resistance of the water to the effects of acids. Expressed as calcium carbonate.
Aluminum (mg/L)	N/A	2	0.02 - 0.03	N/A	May be naturally present.
Ammonia Nitrogen (mg/L)	N/A	2	<0.05	N/A	Occurs naturally from organic nitrogen containing compounds.
Antimony (mg/L)	N/A	0	N/A	N/A	Discharge from petroleum refineries; fire retardants; ceramics; electronics; solder
Arsenic (mg/L)	N/A	2	0.0008 - 0.0009	N/A	Naturally occurring in surface waters / mine drainage
Barium (mg/L)	N/A	0	N/A	N/A	Erosion of natural deposits. Discharge from metal refineries, oil drilling wastes.
Boron (mg/L)	N/A	0	N/A	N/A	Erosion of natural deposits, industrial waste effluents.
Cadmium (mg/L)	N/A	0	N/A	N/A	Industrial discharge
Calcium (mg/L)	N/A	3	32.7 - 36.5	N/A	Naturally occurring.
Chloride (mg/L)	N/A	2	23.0 - 24	N/A	A common naturally occurring non-toxic material that may produce a salty taste in water.

**DOCUMENT:**  
King Street Water Treatment Plant Annual Report

<b>Parameter</b>	<b>MAC</b>	<b>Number of Samples</b>	<b>Results Range (min - max)</b>	<b>MAC Exceedance (Yes or No)</b>	<b>Parameter Description</b>
Chromium (mg/L)	N/A	0	N/A	N/A	Industrial residues
Colour (TCU)	N/A	12	Under 2 - 3	N/A	Typically the result of organic matter in surface waters.
Conductivity (Us / cm)	N/A	2	306 - 316	N/A	A measure of ability of water to carry an electric current due to the presence of ions.
Copper (mg/L)	1 OG	2	Under 0.002	N/A	Domestic plumbing (Aesthetic objective)
Dissolved Organic Carbon (mg/L)	N/A	4	2.6 - 3.6	N/A	High DOC is an indicator of potential for chlorination by-product problems.
Fluoride (mg/L)	N/A	4	Under 0.1 - 0.1	N/A	Naturally occurring.
Hardness (mg/L)	N/A	4	117 - 130	N/A	Naturally occurring from dissolved calcium and magnesium.
Iron (mg/L)	N/A	2	Under 0.005 - 0.007	N/A	Leaching from natural deposits and plumbing materials, industrial wastes. (Aesthetic objective)
Lead (mg/L)	N/A	10	Under 0.00002 - 0.00003	N/A	Internal corrosion of household plumbing, erosion of natural deposits.
Manganese (mg/L)	N/A	2	Under 0.001 - 0.004	N/A	Erosion of natural deposits.
Microcystin (µg/L)	N/A	22	Under 0.15	N/A	Naturally occurring (released from blooms of blue-green algae)
Nitrate (mg/L)	N/A	4	0.19 - 0.42	N/A	Runoff from fertilizer use, erosion of natural deposits
Nitrite (mg/L)	N/A	4	Under 0.05	N/A	A natural component of water at this level.
Nitrioltriactic Acid (mg/L)	0.4	0	N/A	No	A human made organic compound
N-Nitrosodimethylamine (mg/L)	0.0009	0	N/A	No	An organic chemical often found as an industrial biproduct
pH	N/A	12	6.78 - 8.13	N/A	An indicator of the acidity of water.
Selenium (mg/L)	N/A	0	N/A	N/A	Discharge from refineries, mines, chemical manufacture
Sodium (mg/L)	20	4	13.1 - 14.4	No	Occurs naturally in the earth's crust.
Sulphate (mg/L)	N/A	4	21 - 23	N/A	An inorganic constituent that may cause tastes at high levels.

**DOCUMENT:**  
King Street Water Treatment Plant Annual Report

Parameter	MAC	Number of Samples	Results Range (min - max)	MAC Exceedance (Yes or No)	Parameter Description
Total Kjeldahl Nitrogen (mg/L)	N/A	4	0.1 - 0.3	N/A	Indicator of organic contamination or the potential for taste and odour problems.
Total Phenols (mg/L)	N/A	4	Under 0.001 - 0.001	N/A	A chemical compound found in nature and used in a wide variety of products.
Uranium (mg/L)	N/A	0	N/A	N/A	Erosion of natural deposits.
Zinc (mg/L)	N/A	2	Under 0.005	N/A	An inorganic constituent that may cause tastes.

**Table 7 - Treated Water Schedule 23 Inorganic Parameters**

Parameter	MAC	Number of Samples	Results Range (min - max)	MAC Exceedance (Yes or No)	Parameter Description
Antimony (mg/L)	0.006	2	0.0001 - 0.0001	No	Discharge from petroleum refineries; fire retardants; ceramics; electronics; solder
Arsenic (mg/L)	0.025	2	0.0005 - 0.0006	No	Naturally occurring in surface waters / mine drainage
Barium (mg/L)	1	2	0.023 - 0.024	No	Erosion of natural deposits. Discharge from metal refineries, oil drilling wastes.
Boron (mg/L)	5	2	0.020 - 0.021	No	Erosion of natural deposits, industrial waste effluents.
Cadmium (mg/L)	0.005	2	Under 0.000015	No	Industrial discharge
Chromium (mg/L)	0.05	2	Under 0.001	No	Industrial residues
Mercury (mg/L)	0.001	2	Under 0.00002 - 0.00002	No	Erosion of natural deposits, industrial discharges.
Selenium (mg/L)	0.01	2	Under 0.001	No	Discharge from refineries, mines, chemical manufacture
Uranium (mg/L)	0.02	2	0.00008 - 0.00033	No	Erosion of natural deposits.

**Table 8 - Treated Water Schedule 24 Inorganic Parameters**

Parameter	MAC	Number of Samples	Results Range (min - max)	MAC Exceedance (Yes or No)	Parameter Description
Alachlor (µg/L)	5	2	Under 0.3	No	Agricultural herbicide
Atrazine + N-Dealkylated Metabolites (µg/L)	5	2	Under 0.5	No	Agricultural herbicide
Azinphosmethyl (µg/L)	20	2	Under 1	No	Insecticide

**DOCUMENT:**  
King Street Water Treatment Plant Annual Report

<b>Parameter</b>	<b>MAC</b>	<b>Number of Samples</b>	<b>Results Range (min - max)</b>	<b>MAC Exceedance (Yes or No)</b>	<b>Parameter Description</b>
Benzene (µg/L)	5	2	Under 0.5	No	Discharge from plastics manufacturing, leaking fuel tanks
Benzo(a)pyrene (µg/L)	0.01	2	Under 0.006	No	Formed from the incomplete burning of organic matter.
Bromoxynil (µg/L)	5	2	Under 0.5	No	Agricultural herbicide
Carbaryl (µg/L)	90	2	Under 3	No	Agricultural/Forestry/ Household insecticide
Carbofuran (µg/L)	90	2	Under 1	No	Agricultural insecticide
Carbon Tetrachloride (µg/L)	5	2	Under 0.2	No	Discharge from chemical and industrial activities
Chlorpyrifos (µg/L)	90	2	Under 0.5	No	Agricultural/ Household insecticide
Diazinon (µg/L)	20	2	Under 1	No	Agricultural/ Livestock Operation/ Residential insecticide
Dicamba (µg/L)	120	2	Under 1	No	Agricultural herbicide
1,2-Dichlorobenzene (µg/L)	200	2	Under 0.5	No	Discharge from industrial chemical factories
1,4-Dichlorobenzene (µg/L)	5	2	Under 0.5	No	Discharge from industrial chemical factories
1,2-Dichloroethane (µg/L)	5	2	Under 0.5	No	Discharge from industrial chemical factories
1,1-Dichloroethylene (µg/L)	14	2	Under 0.5	No	Discharge from industrial chemical factories
Dichloromethane (µg/L)	50	1	Under 5	No	Discharge from pharmaceutical and chemical factories
2,4-Dichlorophenol (µg/L)	900	2	Under 0.2	No	Industrial contamination/ reaction with chlorine
2,4-Dichlorophenoxy Acetic Acid (µg/L)	100	2	Under 1	No	Agricultural/ Residential herbicide
Diclofop-methyl (µg/L)	9	2	Under 0.9	No	Agricultural herbicide
Dimethoate (µg/L)	20	2	Under 1	No	Agricultural/ Livestock Operation/ Forestry insecticide
Diquat (µg/L)	70	2	Under 5	No	Agricultural/ Aquatic herbicide
Diuron (µg/L)	150	2	Under 5	No	Agricultural/ Industrial/ herbicide
Glyphosate (µg/L)	280	2	Under 25	No	Agricultural/Forestry/ Household herbicide
Malathion (µg/L)	190	2	Under 5	No	Fruit & Vegetable / pest control insecticide

**DOCUMENT:**  
King Street Water Treatment Plant Annual Report

<b>Parameter</b>	<b>MAC</b>	<b>Number of Samples</b>	<b>Results Range (min - max)</b>	<b>MAC Exceedance (Yes or No)</b>	<b>Parameter Description</b>
2-methyl-4-chlorophenoxyacetic Acid (µg/L)	100	2	Under 10	No	Leaching and/or runoff from agricultural and other uses
Metolachlor (µg/L)	50	2	Under 3	No	Agricultural herbicide
Metribuzin (µg/L)	80	2	Under 3	No	Agricultural herbicide
Monochlorobenzene (µg/L)	80	2	Under 0.5	No	Discharge from industrial and agricultural chemical factories and dry cleaning facilities
Paraquat (µg/L)	10	2	Under 1	No	Agricultural/ Aquatic herbicide
Pentachlorophenol (µg/L)	60	2	Under 0.2	No	Pesticide/ wood preservative residue
Phorate (µg/L)	2	2	Under 0.3	No	Agricultural insecticide
Picloram (µg/L)	190	2	Under 5	No	Industrial herbicide
Polychlorinated Biphenyls (µg/L)	3	2	Under 0.05	No	Residue from various industrial uses
Prometryne (µg/L)	1	2	Under 0.1	No	Agricultural herbicide
Simazine (µg/L)	10	2	Under 0.5	No	Agricultural herbicide or its residue
Terbufos (µg/L)	1	2	Under 0.5	No	Agricultural insecticide
Tetrachloroethylene (µg/L)	30	2	Under 0.5	No	Leaching from PVC pipes; discharge from factories, dry cleaners and auto shops (metal degreaser)
2,3,4,6-Tetrachlorophenol (µg/L)	100	2	Under 0.2	No	Wood preservative
Triallate (µg/L)	230	2	Under 10	No	Agricultural herbicide
Trichloroethylene (µg/L)	5	2	Under 0.5	No	Discharge from metal degreasing sites and other factories
2,4,6-Trichlorophenol (µg/L)	5	2	Under 0.2	No	Pesticide manufacturing
Trifluralin (µg/L)	45	2	Under 0.5	No	Agricultural herbicide
Vinyl Chloride (µg/L)	2	2	Under 0.2	No	Leaching from PVC pipes; discharge from plastics factories

**Table 9 - Other Regulatory Treated Water Parameters**

<b>Parameter</b>	<b>MAC</b>	<b>Number of Samples</b>	<b>Results Range (min - max)</b>	<b>MAC Exceedance (Yes or No)</b>	<b>Parameter Description</b>
Fluoride (mg/L)	1.5	4	Under 0.1 - 0.1	No	Naturally occurring.
Nitrite (mg/L)	1	12	Under 0.05 - 0.06	No	A natural component of water at this level.
Nitrate (mg/L)	10	12	0.13 - 0.31	No	Runoff from fertilizer use, erosion of natural deposits
Sodium (mg/L)	20	2	15.3 - 16.6	No	Occurs naturally in the earth's crust. Notification is required every 60 months if greater than 20 mg/L



**Table 10 - Treated Water Testing**  
(Analyzed by Accredited Laboratories)

Parameter	MAC	Number of Samples	Results Range (min - max)	MAC Exceedance (Yes or No)	Parameter Description
Alkalinity CaCO <sub>3</sub> (mg/L)	N/A	4	98 - 103	N/A	Discharge from petroleum refineries; fire retardants; ceramics; electronics; solder
Aluminum (mg/L)	0.1 OG	12	0.04 - 0.15	N/A	Naturally occurring in surface waters / mine drainage
Ammonia Nitrogen (mg/L)	N/A	4	Under 0.05 - 0.17	N/A	Erosion of natural deposits. Discharge from metal refineries, oil drilling wastes.
Calcium (mg/L)	N/A	4	31.7 - 36.9	N/A	Erosion of natural deposits, industrial waste effluents.
Chloride (mg/L)	250	4	25.0 - 27.1	No	Industrial discharge
Colour (TCU)	5	12	Under 2	No	Industrial residues
Conductivity (Us/cm)	N/A	4	316 - 326	N/A	Erosion of natural deposits, industrial discharges.
Cyanide (mg/L)	0.2	0	N/A	N/A	Discharge from refineries, mines, chemical manufacture
Dissolved Organic Carbon (mg/L)	N/A	4	2.2 - 4.1	N/A	Erosion of natural deposits.
Gross Alpha (Bq/L)	0.5	0	N/A	No	Measure of radioactivity
Gross Beta (Bq/L)	1	0	N/A	No	Measure of radioactivity
Total Haloacetic acids (mg/L)	0.08 (Annual Average)	12	0.0053 - 0.0064	No	By-product of drinking water disinfection with chlorine. Based on a running annual average
Hardness (mg/L)	100 OG	4	114 - 131	N/A	Naturally occurring from dissolved calcium and magnesium.
Iron (mg/L)	0.3 AO	4	Under 0.005	N/A	Leaching from natural deposits and plumbing materials, industrial wastes. (Aesthetic objective)
Lead (mg/L)	0.01	8	Under 0.00002 - 0.00021	No	Internal corrosion of household plumbing, erosion of natural deposits.
Manganese (mg/L)	0.05 AO	4	Under 0.001	N/A	Erosion of natural deposits.
Microcystin (µg/L)	1.5	6	Under 0.15	No	Naturally occurring (released from blooms of blue-green algae)

DOCUMENT:  
King Street Water Treatment Plant Annual Report

Parameter	MAC	Number of Samples	Results Range (min - max)	MAC Exceedance (Yes or No)	Parameter Description
Nitrilotriacetic acid/NTA (mg/L)	N/A	0	N/A	N/A	A human made organic compound
N-Nitrosodimethylamine (µg/L)	N/A	0	N/A	N/A	An organic chemical often found as an industrial byproduct
pH	N/A	12	7.75 - 8.19	N/A	An indicator of the acidity of water.
Sulphate (mg/L)	500 OG	4	21 - 23	N/A	An inorganic constituent that may cause tastes at high levels.
Total Trihalomethanes (µg/L)	100 (Annual avg.)	12	11 - 21	No	By-product of chlorination. * The MAC for THMs of 100 µg/L is based on a running annual average.
Total Kjeldahl Nitrogen (mg/L)	N/A	4	Under 0.1 - 0.3	N/A	Indicator of organic contamination or the potential for taste and odour problems.
Tritium (bg/L)	N/A	0	N/A	N/A	A form of hydrogen
Zinc (mg/L)	5	4	Under 0.005	No	An inorganic constituent that may cause tastes.

Table 11 - Regulatory Distribution Water Testing

Parameter	MAC	Number of Samples	Results Range (min - max)	MAC Exceedance (Yes or No)	Parameter Description
Total Haloacetic Acids (mg/L)	0.08 (Annual avg.)	12	0.0064 - 0.0385	No	By-product of drinking water disinfection with chlorine. Based on a running annual average
Total Trihalomethanes (µg/L)	100 (Annual avg.)	12	24 - 80	No	By-product of chlorination. * The MAC for THMs of 100 µg/L is based on a running annual average.

Table 12 - Lead Testing

(Under Schedule 15.1 of Regulation 170/03)

Parameter	MAC mg/L	Number of Sample Locations	Results Exceeding 0.01 mg/L	Results Range mg/L (min - max)	pH Range (min - max)	Alkalinity (CaCO <sub>3</sub> ) Range mg/L (min - max)
Residential	0.01	30	0	0.00002 - 0.00678	7.35 - 7.97	N/A
Non-Residential	0.01	17	0	0.00002 - 0.00188	7.04 - 8.2	96 - 110

**Table 13 - Distribution Water Testing**  
(Analyzed by Accredited Laboratories)

Parameter	MAC	Number of Samples	Results Range (min - max)	MAC Exceedance (Yes or No)	Parameter Description
Alkalinity CaCO <sub>3</sub> (mg/L)	N/A	18	91 - 110	N/A	A measure of the resistance of the water to the effects of acids. Expressed as calcium carbonate.
Aluminum (mg/L)	0.1 OG	8	0.04 - 0.12	N/A	May be naturally present or a residual from the coagulation process.
Ammonia Nitrogen (mg/L)	N/A	8	Under 0.05 - 0.09	N/A	Occurs naturally from organic nitrogen containing compounds.
Arsenic (mg/L)	0.025	2	0.0004 - 0.0005	No	Naturally occurring in surface waters / mine drainage
Benzo(a)-pyrene (µg/L)	N/A	0	N/A	N/A	Formed during the combustion of organic matter
Calcium (mg/L)	N/A	8	30.2 - 38.1	N/A	Naturally occurring.
Chloride (mg/L)	250	8	25.5 - 27.5	No	A common naturally occurring non-toxic material that may produce a salty taste in water.
Colour (TCU)	5	2	Under 2	No	Typically the result of organic matter in surface waters.
Conductivity (Us/cm)	N/A	8	310 - 326	N/A	A measure of ability of water to carry an electric current due to the presence of ions.
Copper (mg/L)	1 OG	8	Under 0.002 - 0.007	N/A	Domestic plumbing (Aesthetic objective)
Cyanide (mg/L)	0.2	0	N/A	N/A	Compound used in a variety of industrial processes
Dissolved Organic Carbon (mg/L)	5 AO	8	1.6 - 2.8	N/A	High DOC is an indicator of potential for chlorination by-product problems.
Fluoride (mg/L)	1.5	2	Under 0.1 - 0.2	No	Naturally occurring.
Gross Alpha (bg/L)	0.5	0	N/A	N/A	Measure of radioactivity
Gross Beta (bg/L)	1	0	N/A	N/A	Measure of radioactivity
Hardness (mg/L)	100 OG	8	112 - 133	N/A	Naturally occurring from dissolved calcium and magnesium.

**DOCUMENT:**  
King Street Water Treatment Plant Annual Report

<b>Parameter</b>	<b>MAC</b>	<b>Number of Samples</b>	<b>Results Range (min - max)</b>	<b>MAC Exceedance (Yes or No)</b>	<b>Parameter Description</b>
Iron (mg/L)	0.3 AO	8	Under 0.005 - 0.046	N/A	Leaching from natural deposits and plumbing materials, industrial wastes. (Aesthetic objective)
Manganese (mg/L)	0.05 AO	8	Under 0.001 - 0.003	N/A	Erosion of natural deposits.
Nitrite (mg/L)	1	2	Under 0.05	No	A natural component of water at this level.
Nitrate (mg/L)	10	2	0.21	No	Runoff from fertilizer use, erosion of natural deposits
Nitrioltriacetic Acid (mg/L)	0.4	0	N/A	N/A	A human made organic compound
Nitrosodimethylamine (µg/l)	0.0009	0	N/A	N/A	An organic chemical often found as an industrial biproduct
pH	6.5–8.5 OG	6	7.46 - 8.01	N/A	An indicator of the acidity of water.
Sodium (mg/L)	20	8	13.9 - 17.4	No	Occurs naturally in the earth's crust.
Sulphate (mg/L)	500 OG	8	21 - 23	N/A	An inorganic constituent that may cause tastes at high levels.
Total Kjeldahl Nitrogen (mg/L)	N/A	8	Under 0.1 - 0.4	N/A	Indicator of organic contamination or the potential for taste and odour problems.
Tritium (bg/L)	7000	0	N/A	No	A form of hydrogen
Zinc (mg/L)	5	8	Under 0.005 - 0.074	No	An inorganic constituent that may cause tastes.

**Table 14 - Raw Water Testing**

(Analyzed by In House Laboratory)

<b>Parameter</b>	<b>MAC</b>	<b>Number of Samples</b>	<b>Average Results</b>	<b>MAC Exceedance (Yes or No)</b>	<b>Parameter Description</b>
Alkalinity (mg/L)	N/A	48	88.9	N/A	A measure of the resistance of the water to the effects of acids. Expressed as calcium carbonate.
Hardness (mg/L)	N/A	47	99.2	N/A	Naturally occurring from dissolved calcium and magnesium.
pH	N/A	365	7.81	N/A	An indicator of the acidity of water
Temperature (°C)	N/A	365	16.32	N/A	Intensity of heat present in a substance or object

**DOCUMENT:**  
**King Street Water Treatment Plant Annual Report**

**Table 15 - Treated Water Testing**

(Analyzed by In House Laboratory)

<b>Parameter</b>	<b>MAC</b>	<b>Number of Samples</b>	<b>Average Results</b>	<b>MAC Exceedance (Yes or No)</b>	<b>Parameter Description</b>
Alkalinity (mg/L)	N/A	49	85.4	N/A	A measure of the resistance of the water to the effects of acids. Expressed as calcium carbonate.
Aluminum (mg/L)	0.1 OG	362	0.071	N/A	May be naturally present or a residual from the coagulation process.
Hardness (mg/L)	100 OG	50	101	N/A	Naturally occurring from dissolved calcium and magnesium.
pH	6.5 - 8.5 OG	365	7.81	N/A	An indicator of the acidity of water.
Temperature (Degrees Celsius)	N/A	365	12.6	N/A	Intensity of heat present in a substance or object